

PRODUCT TECHNICAL DATASHEET

BI/004

Brushless 

Intensive use 

Digital Encoder 



CODE	DESCRIPTION	PCS/PALLET
BI/004	36V DC BIONIK BRUSHLESS barrier for 3 or 4 metre booms, with control unit and on board native encoder, complete with a fastening base with tie rods and screws and boom fastening angles.	8

PRODUCT TECHNICAL SPECIFICATIONS	
Barriers	Up to 4mt long
Power line supply	230V AC - 50 Hz
Motor power supply	36V DC
Electrical absorption	0-15A
Power rating	220W
Frequency of use	Continue
Torque	0 - 200 N m
Operating temperature	- 20 + 55 C°
Protection level	IP54
Reductor Type	Irreversible
Opening time	1,5÷6 sec (up to 3 m) - 3÷6 sec (up to 4 m)
Onboard control unit	CTRL Digital Controller 36V DC
Encoder	Digital native encoder + magnetic digital SENSORED, 4096 PPR
Accessories power supply	24V DC
Colour	Cabinet: painted RAL9006 arabesque grey - Head: black arabesque silver painted - Boom support: plastic RAL9005 - Boom: painted RAL9010 matt
Release system	STANDARD Key cylinder - Optional European Cylinder (Cod. RL670)
Batteries recovery	Available (optional)

BUS synchronization Master/Slave	Yes
Operating cycles per day (opening/closing - 24 hours no stop)	5000 cycles
Maximum dimension product in mm (L x W x H)	280 x 210 x 1203
Product weight packed (Kg)	47,5
Number items per pallet	8

PRODUCT DIMENSIONS AND PREPARING FOR INSTALLATION

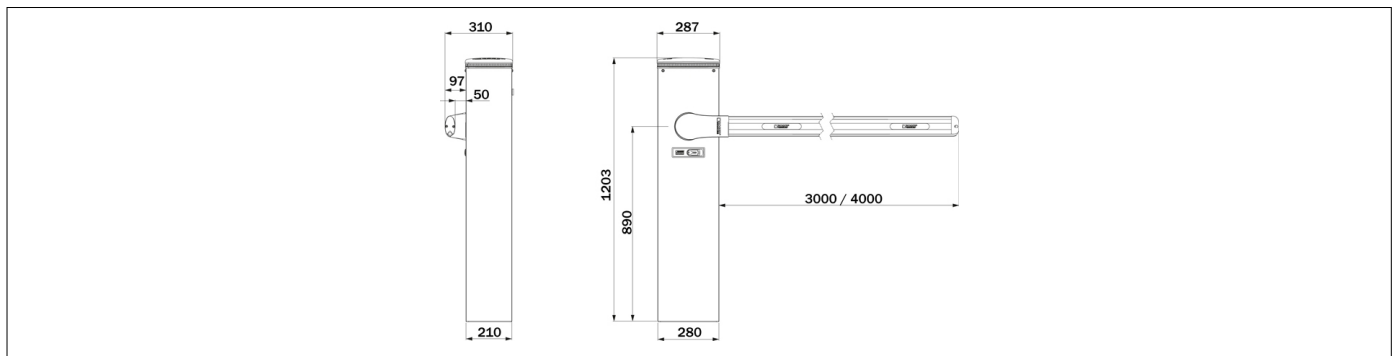

DIMENSIONS

PRODUCT ACCESSORIES

BAFS/01 Fixed support for bars.	BAFS/02 Fixing support, adjustable.	BAFS/03 Fixing support with bolt predisposition for bars.	BAFS/04 Fixing support adjustable, with bolt predisposition for bars.	BAFS/05 Adjustable fixed support with vandal-proof magnetic suction cup complete with B72/DGS demagnetizer card.	BAMS/01 Mobile support for bars.
BAMS/01/EXT Extension 20cm for mobile support BAMS/01.	BA/68/3 White painted aluminum rod, 3 meters long, with LED cover profile and impact resisteng rubber profile.	BA/68/4 White painted aluminum rod, 4 meters long, with LED cover profile and impact resisteng rubber profile.	SND/BA/68/DW Articulated joint 90° with lower tie rod for boom arms BA/68.	SND/BA/68/UP Articulated joint 90° with upper tie rod for boom arms BA/68.	SND/BA/68/UP/RD Articulated joint 90° with upper tie rod (lowered version) for boom arms BA/68.
BARK/02 Barrier skirting in aluminum, with stainless steel screws mounted on bronze bushings. Single module of length 2 meters.	ACS/BA/60 Break-away system for barrier, compatible only with BA/60/3 boom arm.	ACS/BA/68 Break-away system for barrier, compatible with BA/68/3 and BA/68/4 boom arm.	KT247 Support for rectangular boom for BI/004 up to 4 m and max. 3.6 kg.	BI/BAT/KIT Kit for emergency batteries charger for brushless digital controller CTRL 36V DC with plug-in card, with 2 recovery batteries 12V DC, 4.5 Ah. Kit for BIONIK barrier.	BI/BCHP Plug-in card, batteries charger, for brushless digital controller CTRL 36V DC, without recovery batteries, for BIONIK barrier.
BT12V45 Battery 12V 4.5 Ah (1 pc).	B71/PBX36/BOX Battery chargers with solar panels for powering Brushless digital controllers at 36V DC in network assisted.	B71/PBX36/BOX/115 Battery chargers with solar panels for powering Brushless digital controllers at 36V DC in network assisted.	B71/PBX/BOX Battery chargers with solar panels for powering Brushless digital controllers in FULL SOLAR mode.	KT231 Fixing plate for code BAFS/01, BAFS/02, BAFS/03, BAFS/04, BAFS/05.	KT240 Fixing plate with stay bolts and screws for series BIONIK.



B73/EXP
Signal status board, 2 output for CTRL - CTRL/P



B73/LTM
RGB boom light and traffic light control device for CTRL



B74/BCONNECT
Module Wi-Fi B-CONNECT - Management and programming system in IP and CLOUD web mode, via P2P hot spot Wi-Fi connection for 36V Brushless digital controller (B70/2ML - EDGE1 - CTRL - CTRL/P - B70/1DCHP).

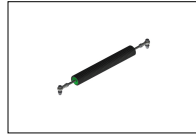

SP/48/01
Spring diameter 48 mm for barriers.

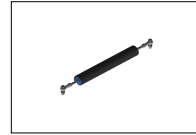

SP/61/01
Spring diameter 61 mm for barriers.

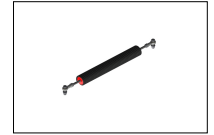

SP/72/01
Spring diameter 72 mm for barriers.



DLD1/24
Loop detector for 1 loop, 2 output, 24V AC/DC.



DLD2/24
Loop detector for 2 loop, 2 output + output alarm, 24V AC/DC.



RL670
European cylinder key for release system series SMARTY - BIONIK.



KT239
Kit DIN rail with magnetic support.



KT242
Cable passage kit with magnetic support for barriers.



ALED/4C
4-metre LED strip with connection cable for barrier boom (red colour).



ALED/4C/RGB
4-metre RGB LED strip with connection cable for barrier boom.



BI/BLED/4/RGB
4-metre RGB LED strip with connection cable for barrier header.



R99/BASB20
Pack of 20 stickers for barrier.



R99/BASB40
Pack of 40 stickers for barrier.